

# PULLMAN-HOLT

## REPLACEMENT PARTS LIST

Save for future reference

### Floor Machines

Models PHC17F, PHC20F

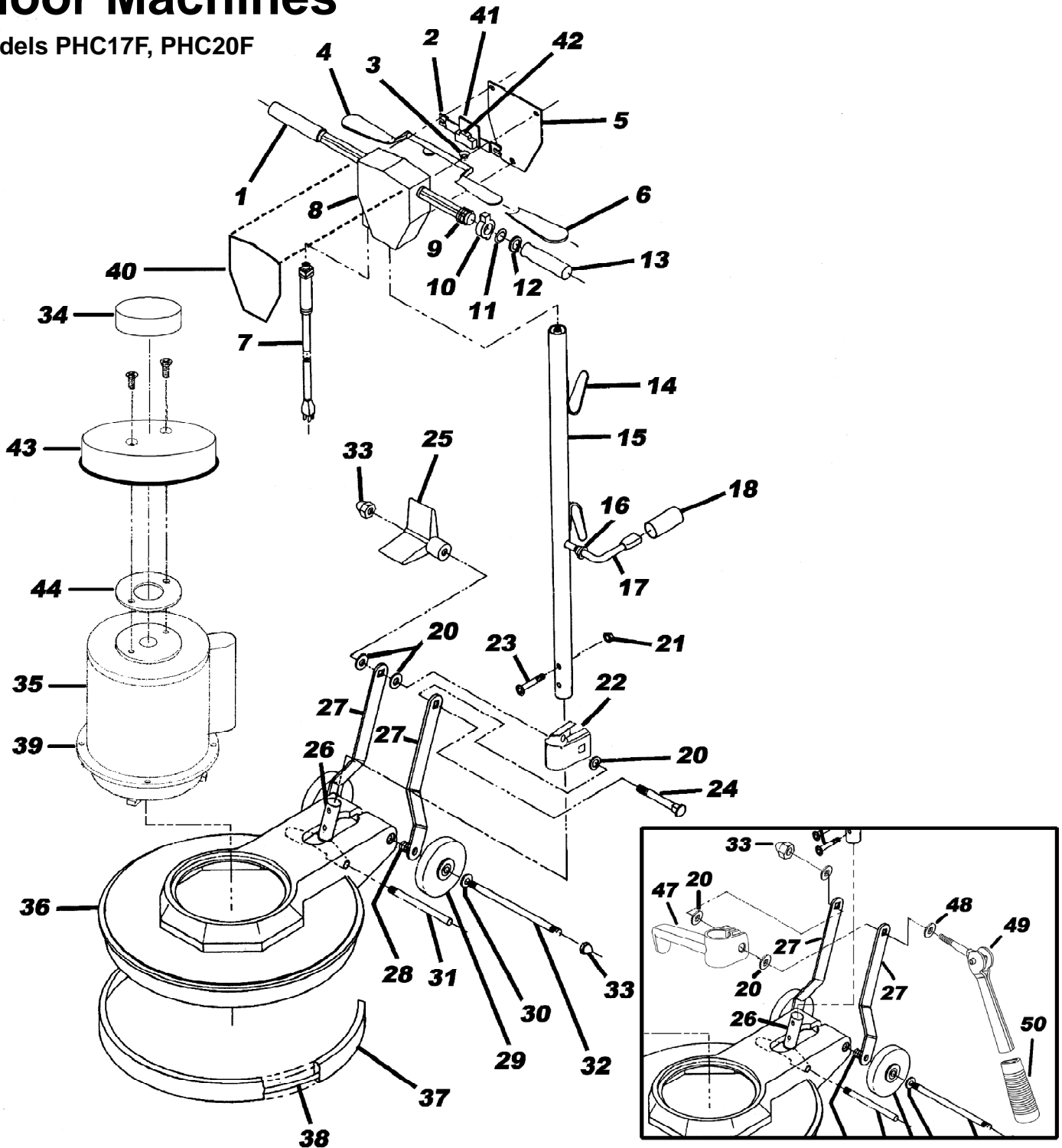

# CHASSIS AND HANDLE ASSEMBLY

Ref.	Part No.	Description	Qty	Ref.	Part No.	Description	Qty
1	B520179	Handle Grip	1	29	B932160	Wheel	2
2	B930431	Switch Assembly Complete	1	31	B932536	Shaft Tee Handle	1
3	B932123	Trigger Spring	1	32	B700958	Axle	1
4	B980302	Trigger	1	33	B521479	Acorn Nut	3
5	B200026	Switch Box Cover	1	34	B200273	Canopy	1
6	B520181	Trigger Sleeve	2	35	B200141	Motor/Gear Assembly 1.5HP 120V/60HZ	1
7	B930404	Cord Set 14/3-50'	1	35	B200297	Motor/Gear Assembly 1.5HP 220V/50HZ	1
8	B200032	Switch Box	1	36	B600636	17" Chassis	1
9	B524548	Spring	1	36A	B600637	20" Chassis	1
10	B524244	Safety Latch	1	37	B230228	17" Chassis Bumper	1
11	B524825	Spacer	1	37A	B230227	20" Chassis Bumper	1
12	B914705	Retaining Ring	1	38	B200023	17" Bumper Insert	1
13	B703518	Handle Grip	1	38A	B200024	20" Bumper Insert	1
14	B932090	Cord Hook	2	40	B160718	Decal	1
15	B600670	Handle Pipe	1	41	B930428	Insulating Board	1
16	B932059	Strain Relief	1	42	B930436	Switch (only)	1
17	B700547	Cord Set 14/3-46"	1	43	B700728	Canopy Bumper	1
18	B525311	Shroud Resistant	1	44	B930522	Canopy Spacer	1
20	B932648	Washer	7	47	B160695	Cast Aluminum Clamp	1
21	B932724	Hex Nut	2	48	B160700	Washer Clamp Double D	1
22	B932079	Handle Clamp	1	49	B160697	Rod and Cam Assembly	1
23	B932653	1/4-20 x 1/2 Bolt	2	50	B160698	Rubber Cam Grip	1
24	B700960	Carriage Bolt	1				
25	B600691	Star Latch	1				
26	B980079	Tee Handle	1				
27	B700957	Strut	2				
28	B520614	Spring	2				