

PHC

OPERATION & CARE INSTRUCTIONS

PHC17F, PHC20F Floor Machines

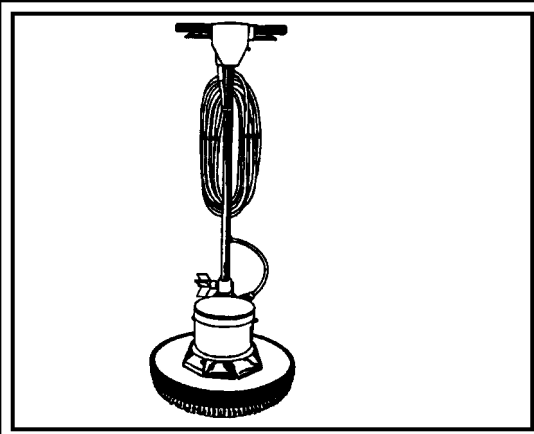

made product. All parts used in manufacturing this floor machine have passed rigid quality control standards prior to assembly and an "each unit" final inspection prior to packaging is your assurance of proper assembly. This floor machine is protectively packed to prevent possible damage in transit. Should damage have occurred, please file a claim immediately with the carrier who delivered the product to you. You must file the freight damage claim. We, as the shipper, cannot do this for you.

SAVE THESE INSTRUCTIONS

IMPORTANT SAFEGUARDS:

Grounding:

This machine must be grounded while in use to protect the operator from electrical shock. The machine is equipped with an approved three-conductor cord and three-prong grounding type plug to fit the proper grounding receptacle. The green (or green and yellow) conductor in the cord is the grounding wire. Never connect the green (or green and yellow) wire to a live terminal.

Warning:

Never operate a machine that is not properly grounded.

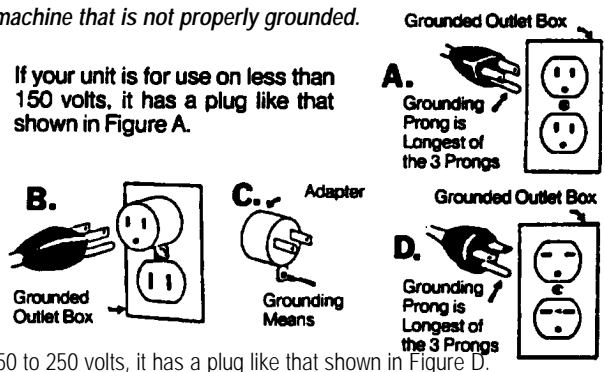

If your unit is for use on less than 150 volts, it has a plug like that shown in Figure A.

If it is for use on 150 to 250 volts, it has a plug like that shown in Figure D.

An adapter, Figures B & C, is available for connecting Figure A plugs to two-plug receptacles. The green-colored rigid ear, plug etc., must be connected to a permanent ground, such as a properly grounded outlet box. No adapter is available for a plug as shown in Figure D. Adapter shown in Figures B & C is not for use in Canada.

Motor:

This machine is powered by a 1 HP (model E) or 1.5 HP (model F) AC motor. Be sure your power supply agrees with the voltage marked on nameplates. Incorrect voltage will cause the motor to draw excessive current resulting in motor burn-out or blown fuse or circuit breaker.

Extension Cords:

Machines that have 3 wire cords requiring grounding must only be used with extension cords that have 3-prong grounding type plugs and 3-pole receptacles. Use only three-wire extension cord.

To determine the minimum wire size required, refer to the chart below:

Chart for minimum wire size (AWG) of extension cord

Nameplate	Total Extension Cord Length - Feet							
Rating - Amps	25	50	75	100	125	150	175	200
0-10.0	18	18	16	16	14	14	12	12
10.1-13.0	16	16	14	14	14	12	12	12
13.1-15.0	12	12	12	12	12	12	12	12

Before using an extension cord, inspect it for loose or exposed wires, damaged insulation and defective plugs.

CAUTION:

Always disconnect power cable from electrical outlet before working on this machine.

CAUTION:

Service and repair should be performed only by a qualified technician. Call 1-800-237-7582 for the location of your nearest Authorized Service Center.

ABOUT THE FLOOR MACHINE

To Assemble:

See instructions, page 3.

To Adjust Handle:

The handle adjustment is controlled by a "star latch" located at the rear of the machine near the bottom of the handle pipe. To release, turn the knob counter-clockwise or by applying foot pressure to the lower portion of the knob. When a convenient handle location for machine operation has been found, lock the handle in place by turning the star knob clockwise to tighten. When transporting the machine or attaching brush/pad be sure the handle is **LOCKED** in the upright position. **NEVER TURN ON THE MACHINE WITH HANDLE IN THE UPRIGHT/LOCKED POSITION.**

Brush Attachment and Removal:

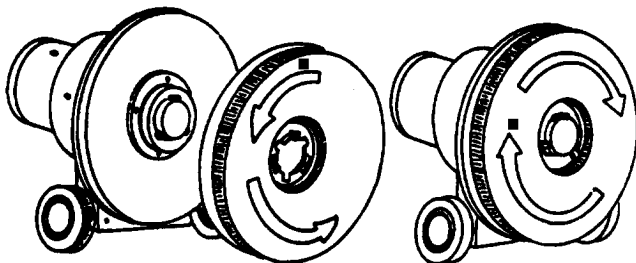

Figure 1

To attach brush

To remove brush

With cable unplugged, **LOCK** handle in upright position and tilt machine back on the handle until the underside of the machine is fully exposed. Select the desired brush, scrub or drive, and position the three slots of the clutch plate over the three lugs of the gearbox. Turn the brush as shown in Fig. 1 as far as it will go. The brush is now seated in ready-to-use position. **TO REMOVE BRUSH**, disengage clutch plate slots from the gear box by turning clockwise. **DO NOT OPERATE THIS MACHINE WITHOUT SCRUB BRUSH OR DRIVE BRUSH AND PAD IN PLACE. NEVER POSITION RUNNING MACHINE OVER AN UNATTACHED BRUSH.**

To Attach a Pad:

If a pad is to be used, a pad drive (not a scrubbing brush) must first be installed as shown in the preceding paragraph. Place the pad on the brush bristles and push the pad firmly onto the brush. Be sure the pad is properly centered on the brush.

To Start:

With the power cable plugged into a proper outlet, release safety latch and squeeze the switch bar beneath the handle grips. This machine is equipped with a mechanical safety lockout on the left handle bar to prevent accidental startup. The lockout must be pushed forward with the operators left thumb before the switch bar can be moved.

To Operate Safety Latch:

The operator must manually rotate the latch with the left thumb before the trigger can be depressed to start brush rotation. When the trigger is released, the safety latch snaps back into position. This will prevent accidental machine startup.

CAUTION: *Machine will immediately veer to one side. Be prepared to control action.*

To Operate:

This machine is designed to move from side to side. To guide right, raise the handle slightly. The higher the handle is raised, the faster the machine will move to the right. Conversely, to guide left, lower the handle. The more the handle is lowered, the faster the machine will move to the left. **WARNING: DO NOT LEAVE A PLUGGED IN MACHINE UNATTENDED.**

Care and Maintenance:

This machine will afford you many years of trouble free service provided it is given proper care. Throwing, dropping, bumping across thresholds and other misuse may result in a damaged unit and invalidate the warranty. For best results, use a clean pad and change frequently as pad loads up. When storing your floor machine, always remove the pad and brush.

Pads can be cleaned by washing in warm water and a mild detergent, rinsing, and hanging up to dry.

Do not lubricate this machine. Lubrication has been applied and permanently sealed at the factory.

Machine Serial Number:

To obtain qualified service, you may need the serial number of the machine when requesting service under warranty or when ordering certain parts. The serial number is found on the data plate located on the machine chassis, not on the motor data plate.

Brush, Floor Machine and Burnisher Size Determination:

The numerals contained within the machine model designation indicate the nominal machine size. In all cases the nominal size is determined by the full spread of the bristles of a long bristle scrub brush on a floor surface when under the weight of a floor machine. The spread of a short or stiff bristle brush will be somewhat less. The brush block diameter will always be two (2) inches less than the nominal brush size, i.e., a 20" brush will have an 18" diameter block. In like manner, the opening on the underside of a machine will be about 1 to 1.5 inches smaller than the nominal machine size, i.e., a 20" machine will have an opening of about 18.5 to 19 inches in diameter.

Warning: **Connect power cord only to an electrical supply the same as shown on the motor data plate. Connecting to the wrong voltage supply will result in damage not covered by warranty and may cause personal injury.**

NOTE: 220 volt machines are shipped without a plug on the end of the power cord due to the many styles of 220 volt plugs in use. Have a qualified electrician attach the proper plug for your location to the cord end.

Warning of Potential Injury:

Moving Parts - To reduce the risk of injury, unplug before servicing.

Fire or Explosion - Do not operate machine in the vicinity of flammable or explosive vapors. Never use flammable liquid to clean a floor.

IMPORTANT INSTRUCTIONS!! INSTRUCCIONES IMPORTANTES!!

Place the machine chassis on a bench or floor with the handle tee stem and the hole in the clamp approximately in line. Position the handle pipe above the clamp with the decal on the switch box facing forward.

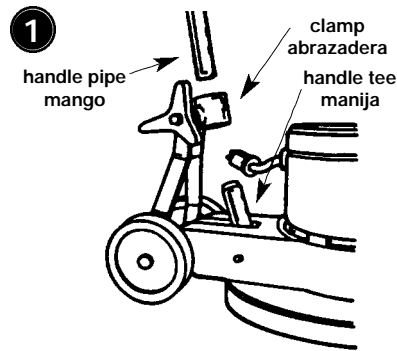

Ponga el chasis de la maquina encima de un banco o en el piso. Alineando la manija con el centro de la abrazadera, coloque el mango encima de la abrazadera con la calcomania hacia el frente.

Push the handle pipe through clamp and over the handle tee stem until the screw holes in the pipe and stem are in alignment.

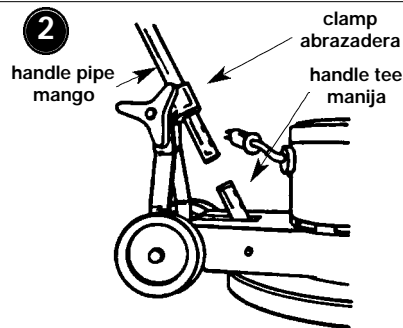

Empuje el tubo de el mango a traves de la abrazadera y colóquelo en la manija, alineando los huecos de los tornillos.

Insert (2) flat head screws through the holes in the pipe and stem with the screw heads facing toward the front of the machine. Assemble the (2) lock nuts to the screws with the lock washer facing toward the pipe.

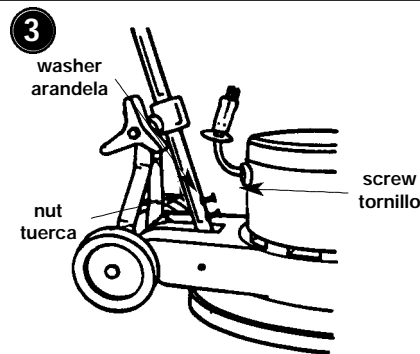

Introduzca (2) tornillos de cabeza plana en los huecos del tubo y la manija, haciendo esto de alante hacia atras de la maquina. Luego ensamble las arandelas y las tuercas (arandela primero y segundo la tuerca).

Tighten the screws and nuts securely with the hex wrench provided.

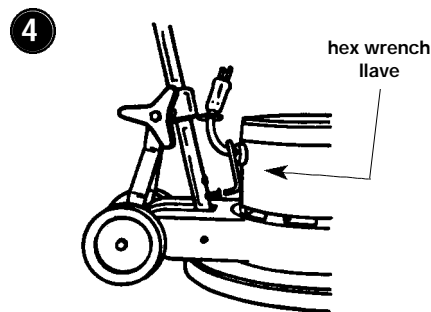

Apriete los tornillos y tuercas con la llave proveida con la maquina.

Plug the motor cord into the handle cord and push the neoprene sleeve over the plugs to seal the plug joint from water entry. Lightly coat the plug surfaces with dishwashing detergent to allow the sleeve to slide freely.

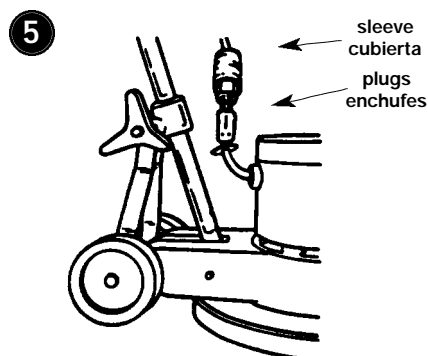

Conecte el enchufe del cable electrico del motor al del cable electrico del mango. Luego lubrique (con liquido detergente) los enchufes en la superficie, para que pueda deslizar la cubierta que protege los mismos contra el agua o humedad.

TROUBLE SHOOTING GUIDE:

<i>PROBLEM</i>	<i>POSSIBLE CAUSE</i>	<i>CORRECTION</i>
Machine won't start.	<ul style="list-style-type: none"> • Power cord not properly plugged into wall outlet. • Blown building fuse or tripped circuit breaker. • Tripped machine circuit breaker (burnishers only). • Damaged power cord or plug. • Broken connection or wire inside switch box. • Failed switch or circuit breaker (burnishers only) inside switch box. • Failed motor capacitor. • Motor pigtail disconnected from handle cord set. • Failed motor. 	<ul style="list-style-type: none"> • Fully engage plug with outlet receptacle. • Replace fuse or reset circuit breaker. • Reset circuit breaker. • Replace with proper 3-wire cord and plug.* • Tighten connection or replace wire.* • Replace switch or circuit breaker.* • Replace capacitor with one identical to the original.* • Connect properly and cover joint with restraint (B525311). • Repair or replace motor.*
Machine starts but won't reach or hold running speed (may be accompanied by a "clicking" noise).	<ul style="list-style-type: none"> • Failed motor starting switch. 	<ul style="list-style-type: none"> • Replace both rotating and stationary portions of switch.*
Machine trips building circuit breaker	<ul style="list-style-type: none"> • Building circuit is overloaded. • An electrical short exists within the machine. • Pad is loaded with dirt or floor finish residue. • Low electrical supply voltage. • Undersized extension cord. 	<ul style="list-style-type: none"> • Remove and turn off other electrical devices on the same circuit or plug machine into a different circuit. • Locate and fix the short.* • Replace and wash pad. • Check voltage at wall outlet with an electrical load on circuit. If less than 108 volts, building wiring is probably inadequate. Plug machine into a different circuit.* • Refer to operation and care instruction for proper cord size.
Circuit breaker in machine switch box trips (burnishers only).	<p>REFER TO SECTION: "MACHINE TRIPS BUILDING CIRCUITBREAKER"</p> <p>Additional burnisher related possible causes:</p> <ul style="list-style-type: none"> • Faulty breaker. • The handle is locked (on "floating head" models). • Using the wring pad. • Using excessive amount of spray buff or restorer. 	<ul style="list-style-type: none"> • Replace breaker. • Unlock the handle to allow machine head to float. • Use buffing pads only. Never use a scrubbing or stripping pad. • Apply these materials very sparingly to a floor. Excessive amounts are not necessary and are sticky and resist pad rotation on the floor.
Operator feels A shock or "tingle" when operating Machine. WARNING: This complaint usually indicates an electrical defect which can result in serious personal injury. Do not continue to operate the machine until corrective action has been completed.	<ul style="list-style-type: none"> • Improper or no ground in wall outlet. • Ground prong damaged or missing on power cord. • Ground (green) wire loose or missing inside switch box. • Terminal or uninsulated wire or stray wire strand in contact with machine frame, handle pipe, or switch box. 	<ul style="list-style-type: none"> • Replace plug or entire cord if damaged.* • Replace or tighten wire.* • Find and repair damaged or dislocated conductor.*
Machine "bogs down" during operation.	<ul style="list-style-type: none"> • Machine underpowered for application EXAMPLE: Using a 3/4 H.P. machine for carpet scrubbing. • Undersized extension cord. • Low electrical supply voltage. 	<ul style="list-style-type: none"> • Use properly powered equipment. • Refer to operation and care instructions for proper cord size. • Check voltage at wall outlet, if less than 108 volts under load, plug machine into a different circuit.